

Hand Sanitizer Kiosk

KHD-2100

Great useful in high-traffic public places

- Hospital
- Catering
- Shopping Mall
- School
- Hotel
- Building
- Supermarket



21.5 inch HD display screen



Auto dispenser

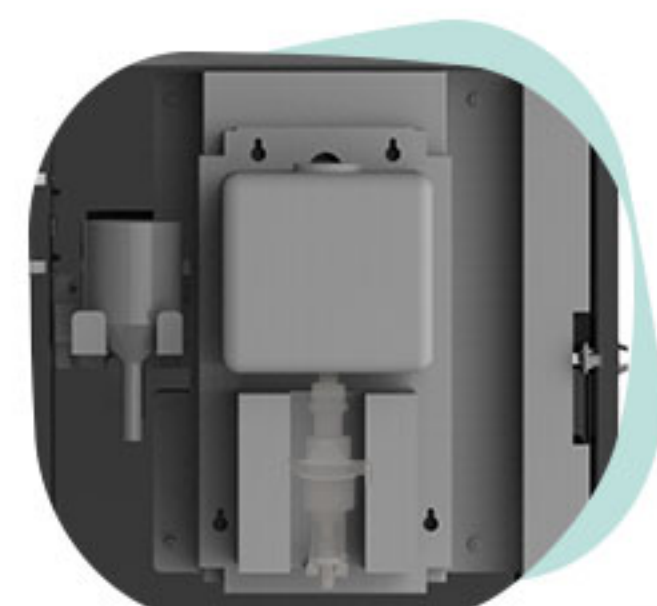

1200ML volume provides 1000 pumps

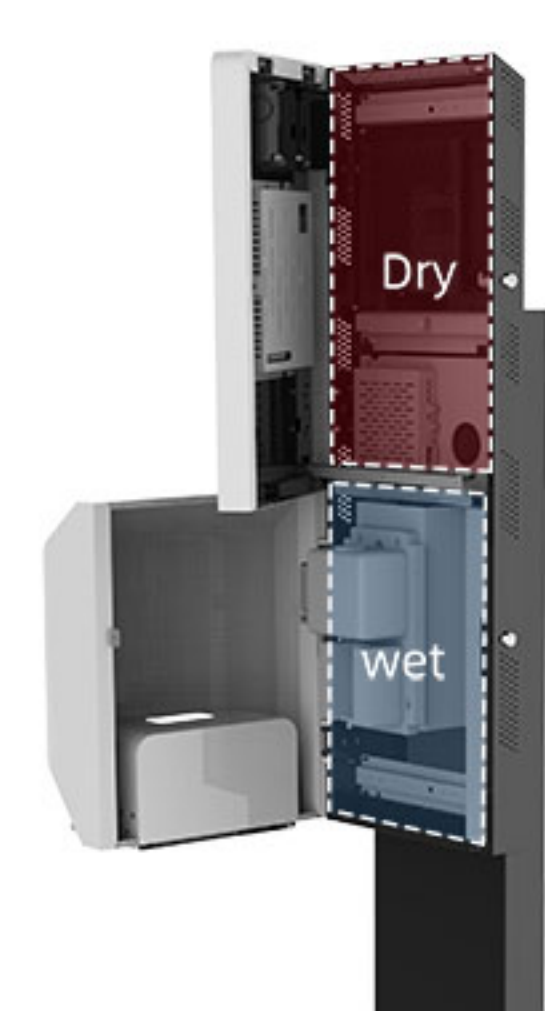

Dry and wet separation



Solid stand and heavy base

Brand It as your need



SPECIFICATIONS

Unit:mm

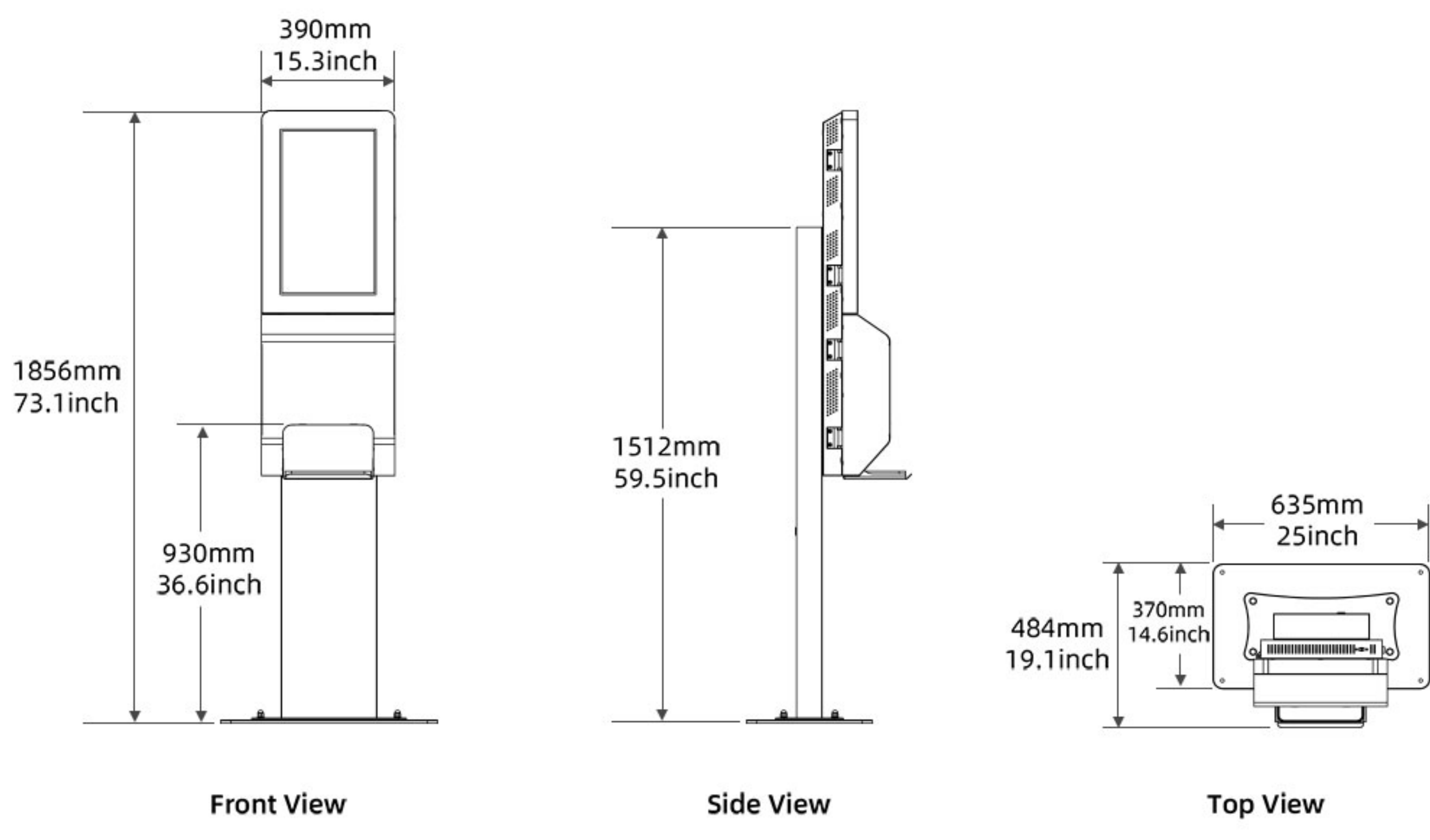

OS Support			
Operating System	WIN 10 (Trial version)	Android 11	
CPU	Intel Celeron J6412 quad-core 2.0G	RK3568 Cortex-A55 quad-core 2.0GHz	
System Memory	4G/8G	2G/4G	
Disk	128G/256G(SSD)	16G/32G/64G	
Speaker	5W*2	5W*2	
Interface	USB*7/RJ45*1	USB*5/RJ45*1	
Network	Ethernet/WIFI	Ethernet/WIFI	
Touch screen			
Type	PCAP 10 points	Response time	10ms
LCD			
Type	TFT-LCD	Contrast Ratio	3000:1
Screen Size	21.5inch	Response Time	18ms
Max Resolution	1920x1080	Viewing Angle	H178° V178°
Aspect Ratio	16:9	Display Colors	16.7M
Brightness	300 cd/m ²	Refresh Rate	60Hz
Panel Life	30000 hours		
Built-in Devices			
Internal Storage Volume	1200ML—provides 1000 pumps		
Power			
Voltage	100-240VAC, 50/60HZ	Power Consumption	<50W
Enclosure			
Material	SPCC	Surface	Powder coating
Net Weight	72kg(flooring) / 32kg(wall mounting)	Gross Weight	117kg
Overall Size	635*484.5*H1856 (flooring) 390*285*H1085 (wall mounting)	Package	1615*680*690mm
colour	Black + White (customized)		
Application			
Working Temperature	0~40°C	Storage Temperature	-20~60°C
Working Humidity	20%~80%	Storage Humidity	10%~90%
Application	Indoor		